

## CILINDROS DE DOBLE EFECTO PARA PRODUCCION



### Ventajas LARZEP

- De 4 a 23 Tn y hasta 260 mm de carrera.
- Para aplicaciones de empuje y tracción.
- Nitrurados para mejorar la resistencia a la corrosión y al desgaste.
- Diseñados para una larga vida en aplicaciones de producción.
- Gran gama de accesorios: brida, soporte para cuerpo, tuerca, rótula. Es necesario utilizar la tuerca para sujetar la brida y el soporte para cuerpo.
- Con rosca métrica, modelos DM o con rosca UN, modelos DI.



Accesorios.

Pág.

73

**Atención: Los modelos DM y DI no están equipados con válvula de seguridad para prevenir sobrepresiones accidentales.**



CILINDROS DE DOBLE EFECTO

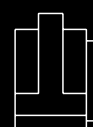

**DM**  
**DI**

CILINDROS

4-23 Tn.

700 bar

## ACCESORIOS PARA CILINDROS DM Y DI

### Tuercas

Modelo	A	B	C	D	E	Peso
LARZEP		mm	mm	mm	mm	kg
DM004RB	M42x1.5	49,5	9,5	6,3	57	0,1
DM008RB	M56x2	65,5	12,7	6,7	75	0,1
DM015RB	M70x2	81,0	19,0	6,7	92	0,4
DM023RB	M85x2	96,5	25,4	6,7	108	0,7

Modelo	A	B	C	D	E	Peso
LARZEP	UN	mm	mm	mm	mm	kg
DI004RB	1 3/8"-12	49,5	9,5	6,3	57	0,1
DI008RB	2"-12	65,5	12,7	6,7	75	0,1
DI015RB	2 5/8"-16	81,0	19,0	6,7	92	0,4
DI023RB	3 1/4"-16	96,5	25,4	6,7	108	0,7

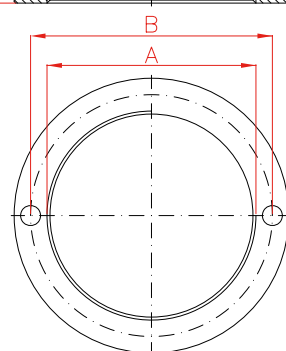
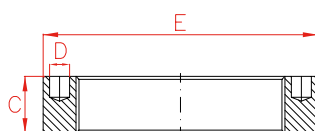

### Rótulas

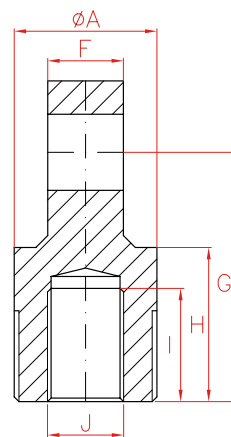
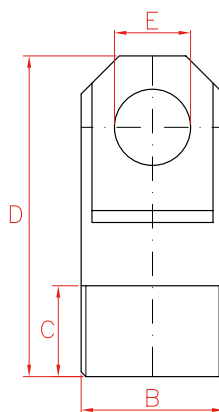

Modelo	A	B	C	D	E	F	G	H	I	J	Peso
LARZEP	mm		mm	mm	mm	mm	mm	mm	mm		kg
DM004RP	30	M30x1.5	19,1	67,4	16	15,9	52,4	32,4	23,8	M16x1,5	0,2
DM008RP	42	M42x1.5	25,4	78,1	20	25,4	57,1	37,1	23,8	M22x1,5	0,6
DM015RP	56	M56x2	25,4	105,8	25	31,9	77,8	52,8	30,2	M30x1,5	1,3
DM023RP	70	M70x2	25,4	112,8	32	38,2	77,8	50,3	27,0	M42x1,5	2,1

Modelo	A	B	C	D	E	F	G	H	I	J	Peso
LARZEP	mm	UN	mm	mm	mm	mm	mm	mm	mm	UN	kg
DI004RP	30	1 1/8"-20	19,1	67,4	16	15,9	52,4	32,4	23,8	1 1/2"-20	0,2
DI008RP	42	1 11/16"-18	25,4	78,1	20	25,4	57,1	37,1	23,8	3/4"-16	0,6
DI015RP	56	2 3/16"-16	25,4	105,8	25	31,9	77,8	52,8	30,2	1 1/8"-12	1,3
DI023RP	70	2 3/4"-16	25,4	112,8	32	38,2	77,8	50,3	27,0	1 1/2"-12	2,1

## ACCESORIOS PARA CILINDROS DM Y DI

### Soportes para cuerpo

Para utilizar este accesorio es necesaria la Tuerca DM\_RB o DI\_RB (pag. 73).



Modelo	A	B	C	D	E	F	G	H	Peso
LARZEP	mm	mm	mm	mm	mm	mm	mm	mm	kg
DM004RC	18	10,5	57,0	31,8	20	80	58,0	42,1	0,4
DM008RC	21	13,5	82,5	44,5	25	105	78,0	56,1	1,2
DM015RC	28	20,0	100,0	52,4	35	127	95,2	70,1	2,9
DM023RC	36	26,5	125,0	63,5	45	159	117,5	85,1	4,5

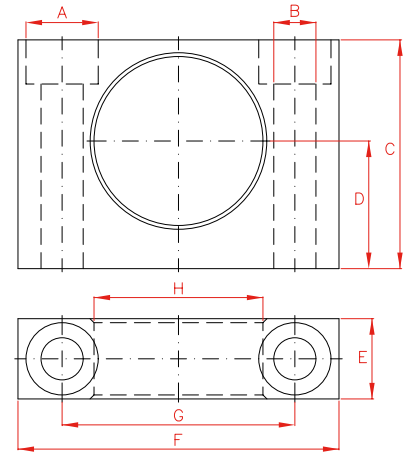

Modelo	A	B	C	D	E	F	G	H	Peso
LARZEP	mm	mm	mm	mm	mm	mm	mm	mm	kg
DI004RC	16	10,5	57,0	31,8	19,3	72,6	50,8	35,1	0,4
DI008RC	20	13,5	82,5	44,5	25,4	101,6	73,2	50,9	1,2
DI015RC	28	20,0	101,6	52,3	35,0	127,0	95,5	66,9	2,9
DI023RC	36	26,5	125,0	63,5	45,0	159,0	117,4	82,7	4,5

NOTA: Los cilindros de 4 Tn tienen puertos de 1/4" BSP para los enchufes.

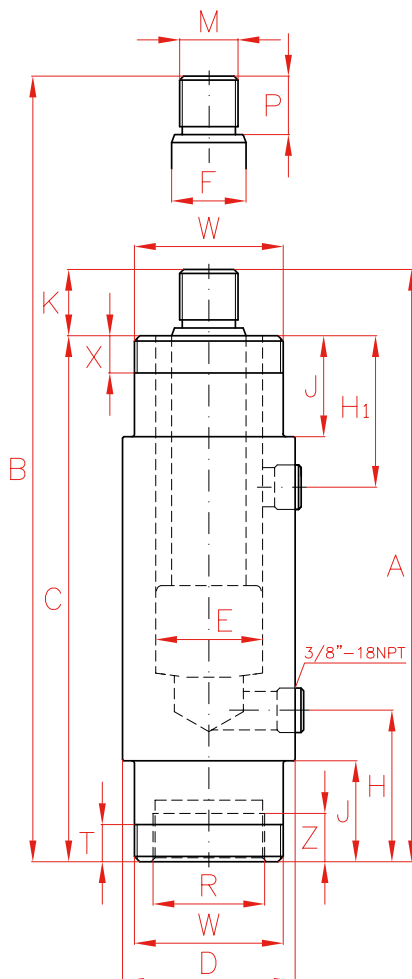

### CILINDROS CON ROSCA METRICA - DM

Capacidad Tn	Carrera mm	Modelo LARZEP	Capacidad (kN)		Area (cm <sup>2</sup> )		Volumen cm <sup>3</sup>	A mm
			Empuje	Tracción	Empuje	Tracción		
4	28	DM00403	34	12	5	2	14	186
	79	DM00408	34	12	5	2	39	237
	155	DM00416	34	12	5	2	76	313
8	28	DM00803	86	44	13	6	35	223
	79	DM00808	86	44	13	6	99	274
	155	DM00816	86	44	13	6	195	350
	257	DM00826	86	44	13	6	323	452
15	159	DM01516	139	73	20	11	323	389
	260	DM01526	139	73	20	11	527	490
23	159	DM02316	228	93	33	14	527	425
	260	DM02326	228	93	33	14	863	526

### CILINDROS CON ROSCA UN - DI

Capacidad Tn	Carrera mm	Modelo LARZEP	Capacidad (kN)		Area (cm <sup>2</sup> )		Volumen cm <sup>3</sup>	A mm
			Empuje	Tracción	Empuje	Tracción		
4	28	DI00403	34	12	5	2	14	186
	79	DI00408	34	12	5	2	39	237
	155	DI00416	34	12	5	2	76	313
8	28	DI00803	86	44	13	6	35	223
	79	DI00808	86	44	13	6	99	274
	155	DI00816	86	44	13	6	195	350
	257	DI00826	86	44	13	6	323	452
15	159	DI01516	139	73	20	11	323	389
	260	DI01526	139	73	20	11	527	490
23	159	DI02316	228	93	33	14	527	425
	260	DI02326	228	93	33	14	863	526

## ACCESORIOS PARA CILINDROS DM Y DI

### Bridas

Para utilizar este accesorio es necesaria la Tuerca DM\_RB o DI\_RB (pag. 73).

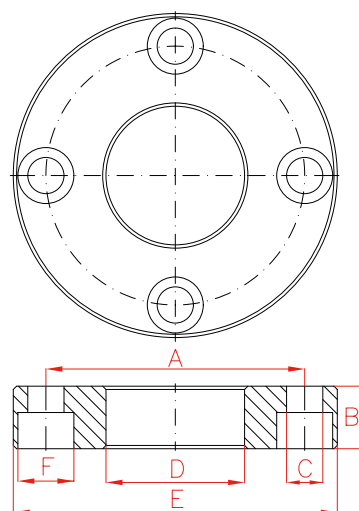

Modelo	A	B	C	D	E	F	Peso
LARZEP	mm	mm	mm	mm	mm	mm	kg
DM004RS	78,6	19,0	11,0	42,1	98,4	17	1,0
DM008RS	98,4	25,4	11,0	56,1	120,5	17	2,1
DM015RS	115,9	35,0	13,4	70,1	143,0	18	3,8
DM023RS	135,7	44,5	17,0	85,1	165,0	22	6,0

Modelo	A	B	C	D	E	F	Peso
LARZEP	mm	mm	mm	mm	mm	mm	kg
DI004RS	78,6	19,0	10,4	35,1	98,4	15	1,0
DI008RS	98,5	25,4	10,5	50,9	120,7	15	2,1
DI015RS	115,9	35,0	13,5	66,8	143,0	20	3,8
DI023RS	135,7	44,5	17,0	82,7	165,0	23	6,0

	B	C	D	E	F	H	H1	K	J	M	P	R	W	X	Z	Peso	Modelo
	mm	mm	mm	mm	mm	mm	mm	mm	mm	mm	mm	mm	mm	mm	mm	kg	LARZEP
	214	162	51	25	20	47	61	24	29	M16x1.5	19	M30x1.5	M42x1.5	11	9	2,0	DM00403
	316	213	51	25	20	47	61	24	29	M16x1.5	19	M30x1.5	M42x1.5	11	9	2,9	DM00408
	468	289	51	25	20	47	61	24	29	M16x1.5	19	M30x1.5	M42x1.5	11	9	3,9	DM00416
	251	198	65	40	28	75	57	25	38	M22x1.5	22	M42x1.5	M56x2	14	14	4,2	DM00803
	353	249	65	40	28	75	57	25	38	M22x1.5	22	M42x1.5	M56x2	14	14	5,3	DM00808
	505	325	65	40	28	75	57	25	38	M22x1.5	22	M42x1.5	M56x2	14	14	6,8	DM00816
	709	427	65	40	28	75	57	25	38	M22x1.5	22	M42x1.5	M56x2	14	14	9,0	DM00826
	548	359	80	51	35	73	95	30	54	M30x1.5	28	M56x2	M70x2	22	24	9,0	DM01516
	750	460	80	51	35	73	95	30	54	M30x1.5	28	M56x2	M70x2	22	24	11,7	DM01526
	584	398	92	65	50	89	110	27	70	M42x1.5	25	M70x2	M85x2	29	26	17,0	DM02316
	786	499	92	65	50	89	110	27	70	M42x1.5	25	M70x2	M85x2	29	26	21,0	DM02326

	B	C	D	E	F	H	H1	K	J	M	P	R	W	X	Z	Peso	Modelo
	mm	mm	mm	mm	mm	mm	mm	mm	mm	UN	mm	UN	UN	mm	mm	kg	LARZEP
	214	162	51	25	20	47	61	24	29	1/2"-20	19	1 1/8"-20	1 3/8"-12	11	9	2,0	DI00403
	316	213	51	25	20	47	61	24	29	1/2"-20	19	1 1/8"-20	1 3/8"-12	11	9	2,9	DI00408
	468	289	51	25	20	47	61	24	29	1/2"-20	19	1 1/8"-20	1 3/8"-12	11	9	3,9	DI00416
	251	198	65	40	28	75	57	25	38	3/4"-16	22	1 11/16"-18	2"-12	14	14	3,7	DI00803
	353	249	65	40	28	75	57	25	38	3/4"-16	22	1 11/16"-18	2"-12	14	14	4,7	DI00808
	505	325	65	40	28	75	57	25	38	3/4"-16	22	1 11/16"-18	2"-12	14	14	6,4	DI00816
	709	427	65	40	28	75	57	25	38	3/4"-16	22	1 11/16"-18	2"-12	14	14	9,0	DI00826
	548	359	80	51	35	73	95	30	54	1 1/8"-12	28	2 3/16"-16	2 5/8"-16	22	24	9,0	DI01516
	750	460	80	51	35	73	95	30	54	1 1/8"-12	28	2 3/16"-16	2 5/8"-16	22	24	11,7	DI01526
	584	398	92	65	50	89	110	27	70	1 1/2"-12	25	2 3/4"-16	3 1/4"-16	29	26	17,0	DI02316
	786	499	92	65	50	89	110	27	70	1 1/2"-12	25	2 3/4"-16	3 1/4"-16	29	26	21,0	DI02326